

cod.	Ø	pz/pcs	tub.	cardine	A	B	C	ØD	ØE	L
861P.30/30	30	10	30	M18	30x30	35	9	Ø29	Ø23	53
861P.35/35	35	10	35	M22	35x35	40	9	Ø34	Ø28	58
861P.40/40	40	6	40	M27	40x40	45	10	Ø39	Ø33	65



Swing gates accessories



Steel components



- Components to weld
- The weld must be adequately sized to support the applied forces and with suitable electrode material.
- Adequately strengthen the areas anchoring the door and/or structure / frame.



Lubricate all parts in contact with grease (every 6 months) .
In case of anomalies, prevent the usage of the hinge and the installed product must be checked by professional personnel.



Responsibly dispose of the product and of its packaging respecting the local legislations of the Country of installation.

The company reserves the right to make technical as well as aesthetic changes without previous notice.
All responsibility due to an inappropriate use of the product is declined.

All drawings, photos, trademarks, logos, are of exclusive Combi Arialdo's property. All uses not expressly authorized by the company will be prosecuted.

1

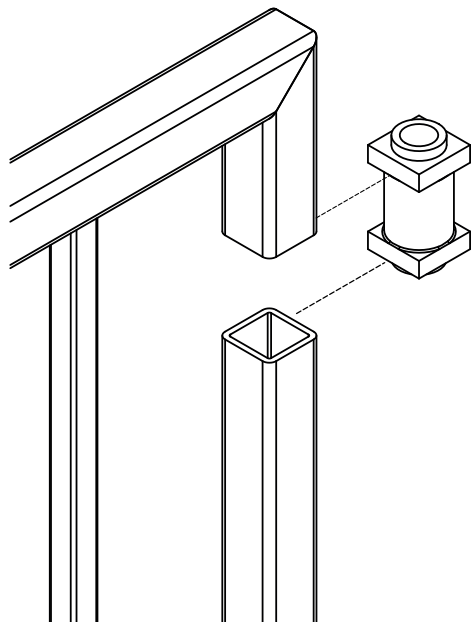

2

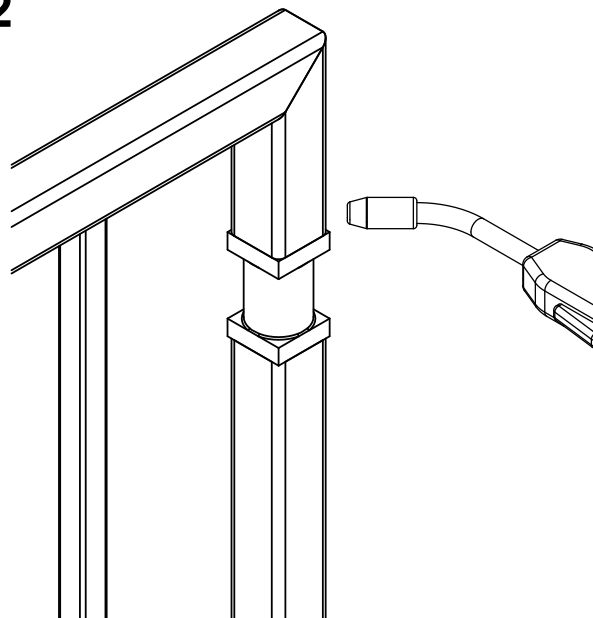

3

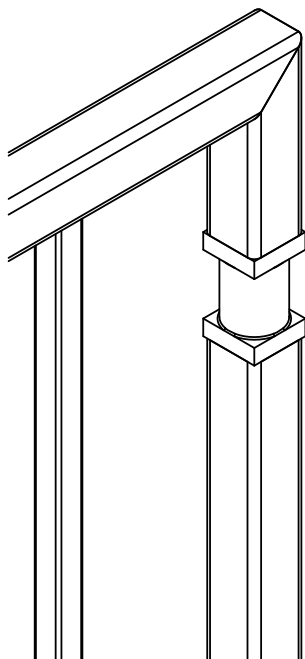

ART. 861 T

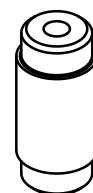

ART. 861 P

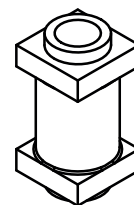

ART. 861 G

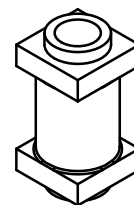

ART. 861 X

